

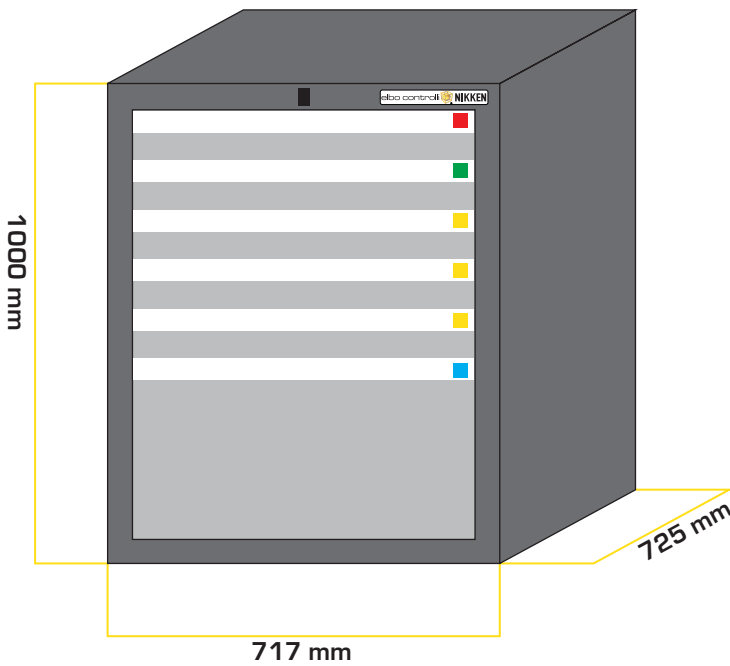

VM4IS

AUTOMATED STORAGE OVERALL DIMENSION AND COMPOSITION:



■ N°1 drawer H 100 mm with mixed locations:
36 compartments (single drawer internal
dimension L: 98 X D: 74,5 X H: 61 mm)



■ N°1 drawer H 100 mm with mixed locations:
16 compartments (single drawer internal
dimension L: 147,5 X D: 123 X H: 61 mm)



■ N°3 drawers L: 702 X D: 713 X H: 100 mm

■ N°1 drawer L: 702 X D: 713 X H: 400 mm

TP32 SOFTWARE INTEGRATION

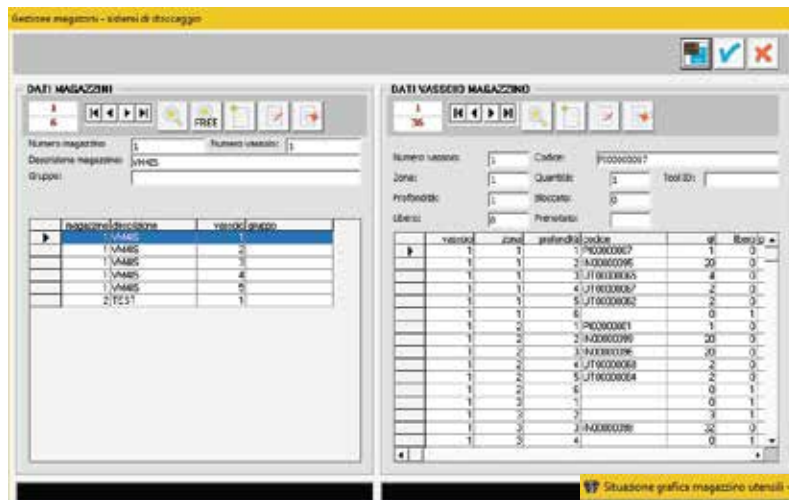

VM4IS: a touch of *simplicity* in your Toolroom

Tp32 software integration will allow you to manage your tool warehouse in a simple and quick way, dialoguing directly with the VM4IS automated storage.

The easy management carries out by directly piloting the movement of the warehouse boxes to perform the operation of loading and unloading of the components.

Tray situation in *real time*

What better way to understand the current status of the warehouse if not in real time?

Tp32 makes this operation intuitive and smart: through a screen are displayed the tray areas occupied (red), the free ones (green) and the those assigned but empty (orange).

Moreover, it's possible to consult the tray current status clicking on the interested area.



"Simplicity is the essence of universality" Mahatma Gandhi